

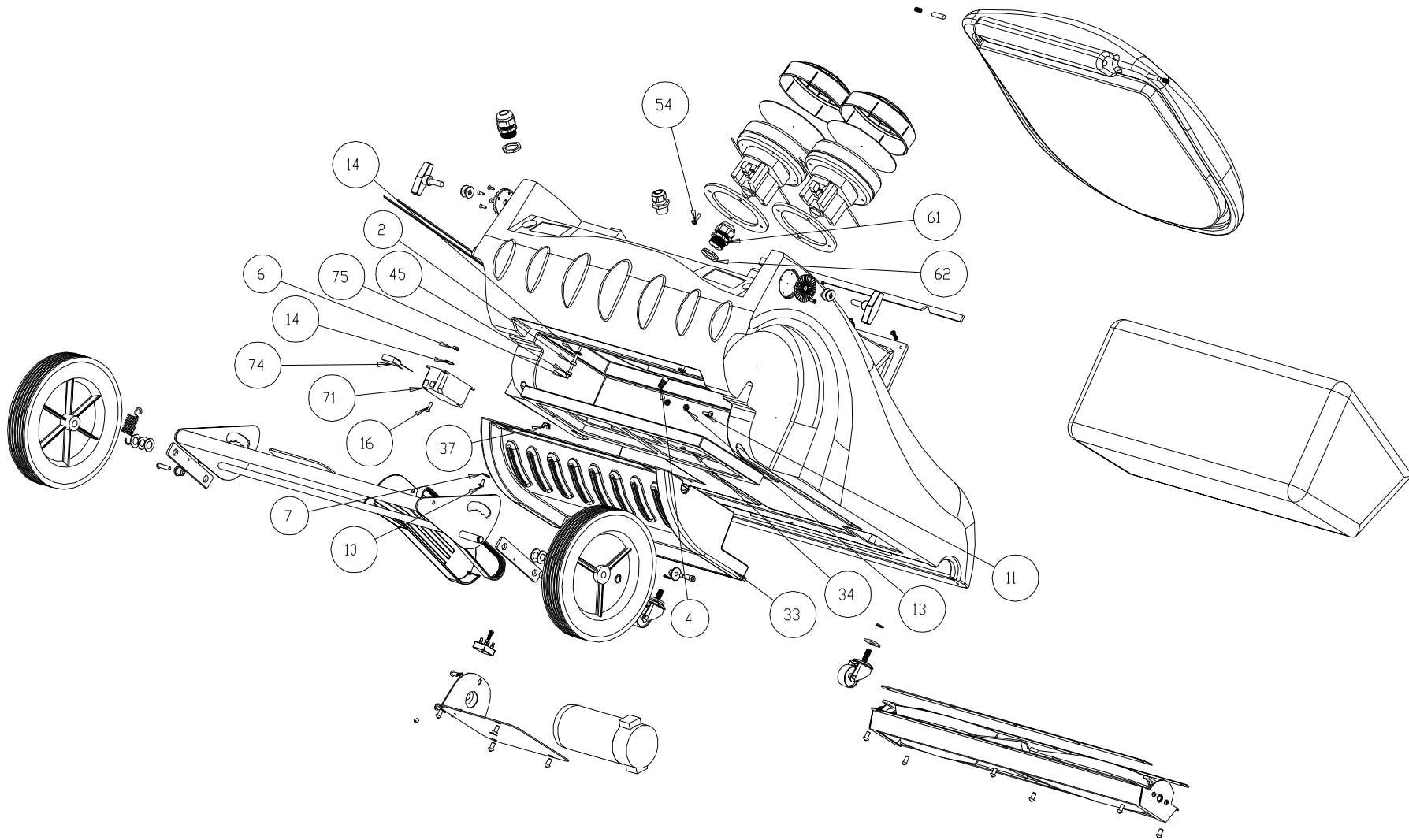

REV	DATE	ECN	DESCRIPTION	BY	MATERIAL	FINISH	Tacony COMMERCIAL FLOOR CARE		3101 Wichita Court Fort Worth, TX 76140-1755	
A	1/2008	10741	NEW RELEASE	KM	DWN KM	-	SCALE	-	SHEET	1 OF 2
B	4/24/09	-	NEW RELEASE	AR	UNLESS OTHERWISE NOTED ALL TOLERANCES ARE ±0.02		TACONY CORPORATION CLAIMS PROPRIETARY RIGHTS IN THE MATERIAL DISCLOSED HEREIN. THIS DRAWING IS ISSUED FOR ENGINEERING INFORMATION ONLY. IT MAY NOT BE REPRODUCED, NOR MAY THE INFORMATION HEREIN BE USED FOR MANUFACTURING PURPOSES WITHOUT WRITTEN PERMISSION FROM TACONY CORP.		DESCRIPTION	WAV, TRUVOX 230V
-	-	-	-	-			A	PART NUMBER	93031TV	REV B

PART NUMBER

93031TV



REV	DATE	ECN	DESCRIPTION	BY	MATERIAL	FINISH
A	1/2008	10741	NEW RELEASE	KM	DWN KM	SCALE
B	4/24/09	-	NEW RELEASE	AR	UNLESS OTHERWISE NOTED ALL TOLERANCES ARE ±0.02	
-	-	-	-	-	TACONY CORPORATION CLAIMS PROPRIETARY RIGHTS IN THE MATERIAL DISCLOSED HEREIN. THIS DRAWING IS ISSUED FOR ENGINEERING INFORMATION ONLY. IT MAY NOT BE REPRODUCED, NOR MAY THE INFORMATION HEREIN BE USED FOR MANUFACTURING PURPOSES WITHOUT WRITTEN PERMISSION FROM TACONY CORP.	

 COMMERCIAL FLOOR CARE		3101 Wichita Court	
		Fort Worth, TX 76140-1755	
DESCRIPTION		WAV, TRUVOX 230V	
A	PART NUMBER	93031TV	REV B

PART NUMBER

93031TV

ITEM	QTY	PART NO.	DESCRIPTION
1	12	00086	SCREW, 1/4"-20 X 1/2"L, RNDHD, PH, ZP
2	2	01604	NUT-FINISHED HEX #10-32
3	1	02011	SCREW, 1/4"-20 X 5/16"L, SET, ALLEN, CUPPNT, BD
4	2	02195	NUT-SCREW CONNECTOR
5	4	02568	WASHER, 0.375", PLAIN, ZP
6	4	02625	NUT-HEX. LOCK (KEPS) #10-32
7	4	00851	WASHER-PLAIN 1/4"
8	2	03321	WASHER, 0.391", PLAIN, ZP
9	2	03536	WASHER, 0.375", LOCK, SPLIT, ZP
10	4	03660	SCREW, #10-24 X 7/16"L, PNHD, PH, ZP
11	1	04735	SCREW-PHILLIPS TRUSS HEAD MACHINE #10-24 X 3/4
12	2	07870	WASHER, 0.25", LOCK, INTERNAL TOOTH, ZP
13	2	10892	NUT-HEX LOCK #10-24
14	6	11385	WASHER, SEALING #10
15	2	11423	BAG, POLY, 20" X 24" *
16	4	12896	SCREW, #10-32 X 5/8"L, RHDHD, PH, ZP
17	1	14142	WASHER, 0.265", PLAIN, ZP
18	2	15162	SCREW, 1/4"-20 X 1/2"L, FHD, PH, ZP
19	2	15357	SPRING, LATCH RELEASE
20	2	16169	NUT-CONDUIT
21	2	18706	WIRE TIE, 15", BLACK
22	8	19255	SCREW, #8-32 X 1/2"L, FHD, SOCKET, BD
23	4	19616	WASHER, 0.563", PLAIN, SS
24	2	19797	WHEEL, 10", PLASTIC HUB
25	2	19798	BRACKET, GROOVED
26	1	19802	BELT, BRUSH DRIVE
27	1	19816	FILTER BAG, CLOTH
28	2	19818	SPRING, WAHSER, 1/2"
29	2	19834	FILTER, VAC INTAKE, 5.8"
30	1	19835	PULLEY, BRUSH, DRIVE
31	1	19836	MOUNT, BRUSH MOTOR
32	2	19841	ARM, WHEEL PIVOT
33	1	19854	COVER, EXHAUST
34	1	19855	EXHAUST FILTER
35	2	19864	PIN, LID HINGE
36	1	19870	ASS'Y, BRUSH
37	2	19975	NUT-WING (10-32) ZINC PL
38	1	19984_230V	ASSEMBLY, HANDLE, WAV
39	2	19999	SCREW, 1/4"-20 X 1-1/4"L, RHDHD, PH, ZP
40	1	33039	CARTON, TRUVOX, W/ LOGO *

ITEM	QTY	PART NO.	DESCRIPTION
41	2	30077	GASKET, BRUSH SHOE
42	1	30078	GASKET, HOOD *
43	2	30088	FILTER, VAC INLET, 5.8"
44	2	30090	GASKET, 5.8" MOTOR
45	2	30358	NUT, NYLON LOCK #10-32
46	2	30461	PIVOT SLEEVE, WHEEL
47	2	30464	PIVOT SLEEVE, WHEEL
48	2	30466	SPRING, TENSION
49	1	30491	ASS'Y, AXLE WHEEL
50	2	30507	SNAP RING, 1/2", EXTERNAL
51	2	30558	KNOB, #3/8-16
52	2	30617	SCREW, 1/4"-20, SHCS, SHOULDER 5/16"D X 3/4"L
53	1	30618	DECAL, CARPET LEVEL *
54	8	30620	SCREW, #10-16 X 3/4"L, PNHD, PH, ZP, TAPTITE
55	2	31209	WHEEL, CASTER
56	2	31306	VAC-MOTOR 240V
57	1	33036	CHASSIS
58	1	33047	DECAL, NO LOGO, TRUVOX, 3.5" X 15.5", BLK*
59	1	33057	BELT COVER
60	1	33061	BRIDGE RECTIFIER, 25 A
61	2	33191	STRAIN RELIEF, LIQ. TITE
62	2	33192	NUT, LOCK, STRAIN RELIEF, NI-PLATE
63	1	33193	FILTER CHUTE
64	4	33195	SCREW, #10-16 X 3/4"L, PNHD, PH, BD, TAP-AB
65	1	33451	SCREW, #10-24 X 5/8"L, PNHD, PH, ZP, TAP-F
66	1	33500	LID
67	1	33501	BRUSH MOTOR, 230V
68	1	33502	GASKET, CHUTE
69	1	33504	WIRING HARNESS, 230V WAV *
70	1	33505	230V POWER CORD 25M *
71	1	33506	EMI FILTER, POWER
72	1	33508	EMI FILTER, MOTOR
73	1	33509	80632 CUT AT 15" L *
74	1	33628	CAPACITOR, EMI FILTER
75	2	33630	SCREW, #10-32 X 3"L
76	1	80632	NEOPRENE GASKET MATERIAL, 1" X 3/8" *
77	1	90701	FILTER BAG, PAPER *
78	2	PD8+	STRAIN RELIEF, LIQ TITE
79	1	X9214+	LABEL, GROUND SYMBOL *
80	1	15139	TERMINAL QD FEMALE 14/16 GA *

*NOT SHOWN

REV	DATE	ECN	DESCRIPTION	BY	MATERIAL	FINISH	Tacony		3101 Wichita Court		
A	1/2008	10741	NEW RELEASE	KM	DWN KM	DATE	SCALE	SHEET	Fort Worth, TX 76140-1755		
B	4/24/09	-	NEW RELEASE	AR	UNLESS OTHERWISE NOTED ALL TOLERANCES ARE ±0.02		TACONY CORPORATION CLAIMS PROPRIETARY RIGHTS IN THE MATERIAL DISCLOSED HEREIN. THIS DRAWING IS ISSUED FOR ENGINEERING INFORMATION ONLY. IT MAY NOT BE REPRODUCED, NOR MAY THE INFORMATION HEREIN BE USED FOR MANUFACTURING PURPOSES WITHOUT WRITTEN PERMISSION FROM TACONY CORP.		DESCRIPTION		
C	8/28/13	-	MOTOR GASKET P/N CHANGE	ND			3 OF 3		WAV, TRUVOX 230V		
								COMMERCIAL FLOOR CARE		REV C	
								PART NUMBER		93031TV	

PART NUMBER

19984

BILL OF MATERIALS

ITEM	QTY	PART NUMBER	DESCRIPTION
1	4	16924	SCREW, #6-32 X 3/4"L, PAN HEAD
2	3	01978	SCREW, 1/4"-20 X 1-1/2"L, RHDHD, PH, ZP
3	1	03261	SCREW, TCT(F) PAN HEAD, #10-32
4	4	18706	WIRE TIE, 15", BLACK
5	1	19357	SWITCH, PUSH BUTTON, DPST, 20A
6	2	19798	BRACKET, GROOVED
7	1	19829	HANDLE, MAIN
8	1	19849	TRIGGER, BRUSH SWITCH
9	4	30074	NUT, HEX #8-32 ZP
10	1	32935	CIRCUIT BREAKER, PUSH BUTTON, 3A
11	1	32964	10 AMP CIRCUIT BREAKER
12	1	32966	SWITCH, ROCKER, DPST, 20A
13	4	33188	SCREW, #8-32 X 1/2"L, FHD, PH, ZP, TAP-F
14	1	33189	SWITCH BOX, TOP
15	1	33190	SWITCH BOX, BOTTOM
16	1	33191	STRAIN RELIEF, LIQ. TITE
17	1	33192	NUT, LOCK, STRAIN RELIEF, NI-PLATE
18	2	33194	SCREW, #6-13 X 1L, PNHD, PH, ZP, PLASTITE
19	1	33452	CONTROL CABLE

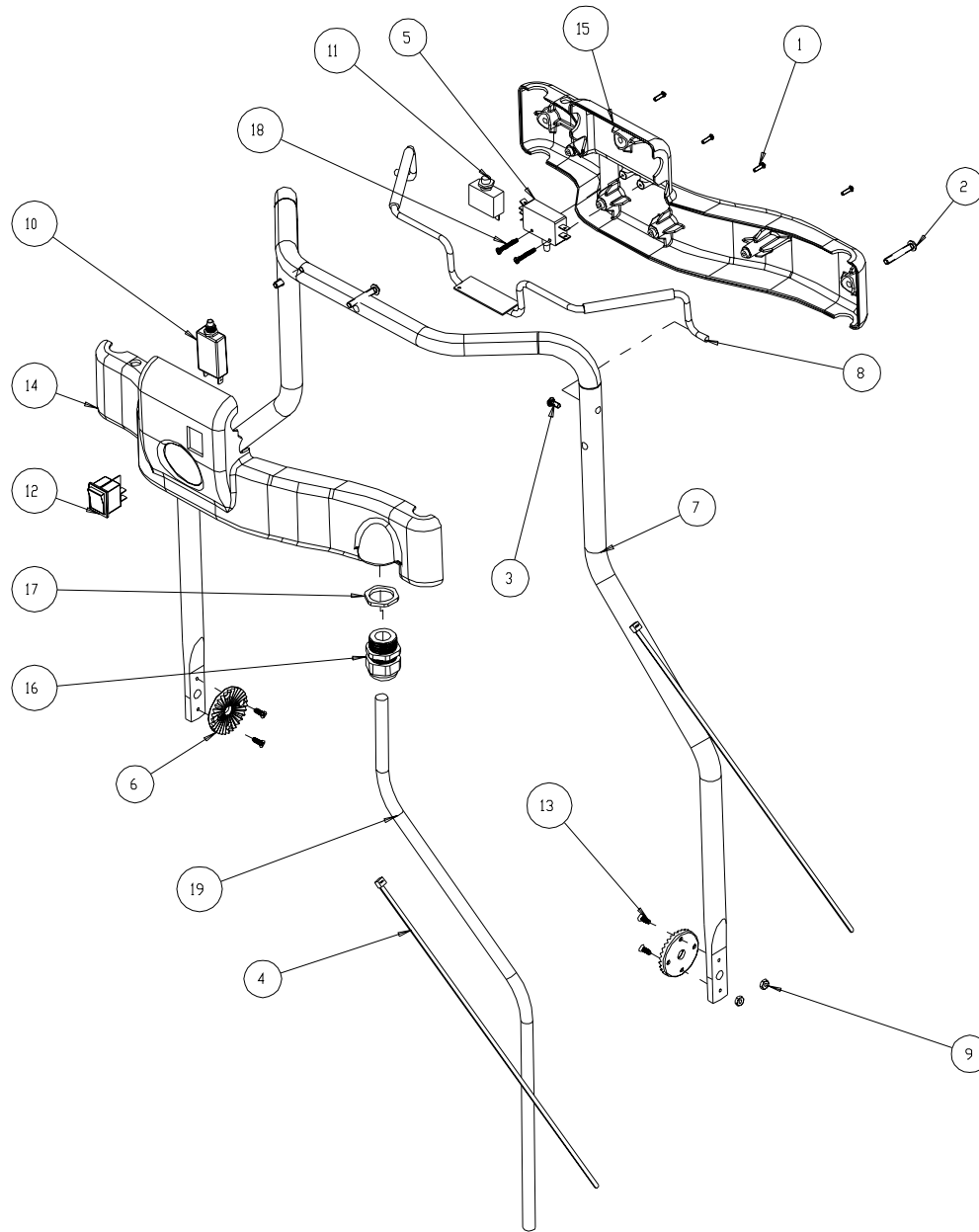

REV	DATE	ECN	DESCRIPTION	BY	MATERIAL	FINISH	Tacony		3101 Wichita Court	
A	4/08	10787	NEW RELEASE	KM	DWN KM	DATE -	SCALE -	SHEET 1 OF 1	Fort Worth, TX 76140-1755	
B	4/24/09	-	NEW RELEASE	AR	UNLESS OTHERWISE NOTED ALL TOLERANCES ARE ±0.02		TACONY CORPORATION CLAIMS PROPRIETARY RIGHTS IN THE MATERIAL DISCLOSED HEREIN. THIS DRAWING IS ISSUED FOR ENGINEERING INFORMATION ONLY. IT MAY NOT BE REPRODUCED, NOR MAY THE INFORMATION HEREIN BE USED FOR MANUFACTURING PURPOSES WITHOUT WRITTEN PERMISSION FROM TACONY CORP.		DESCRIPTION HANDLE, WAV, 230V	
-	-	-	-	-			A PART NUMBER		19984	
									REV	B

PART NUMBER **19984**

BILL OF MATERIALS

ITEM	QTY	PART NO.	DESCRIPTION
1	2	02011	SCREW, 1/4"-20 X 5/16"L, SET, ALLEN, CUPPNT, BD
2	4	07535	SCREW, #8-18 X 3/8"L, PNHD, PH, ZP, TAP-AB
3	2	11276	SCREW, 1/4"-20 X 7/8"L, FHD, PH, ZP
4	4	16142	SCREW, #10-32 X 1/2"L, PNHD, PH, ZP
5	1	19804	PULLEY, BRUSH, DRIVEN
6	2	19805	BEARING BLOCK
7	1	19808	AXLE, BRUSH
8	2	19809	BEARING, SEALED, 6201-2RS
9	1	19810	SHOE, BRUSH MOUNT
10	1	19811	BRUSH, 28"
11	2	19848	THREAD GUARD
12	2	32896	GASKET

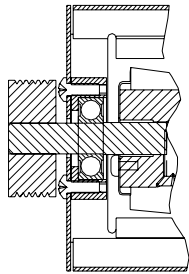
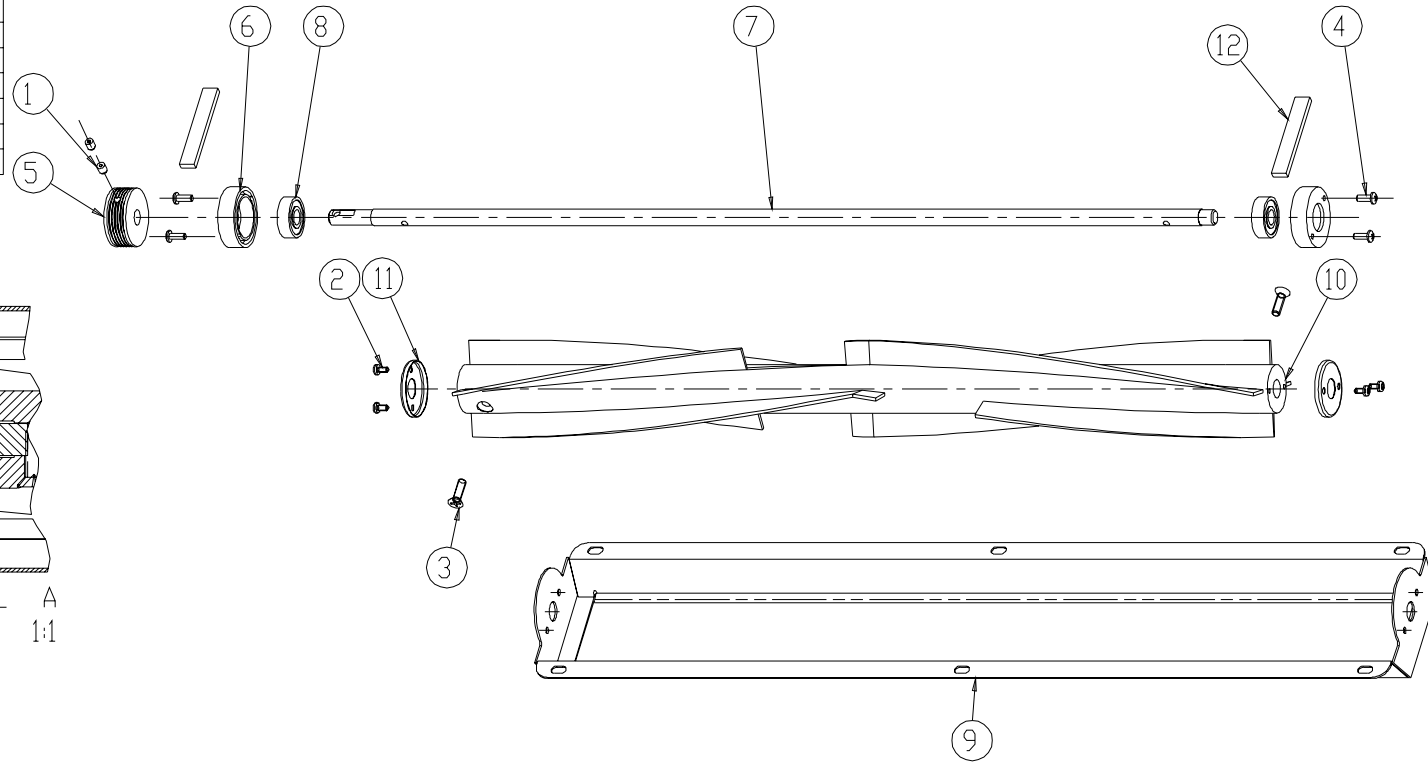

DETAIL A
SCALE 1:1

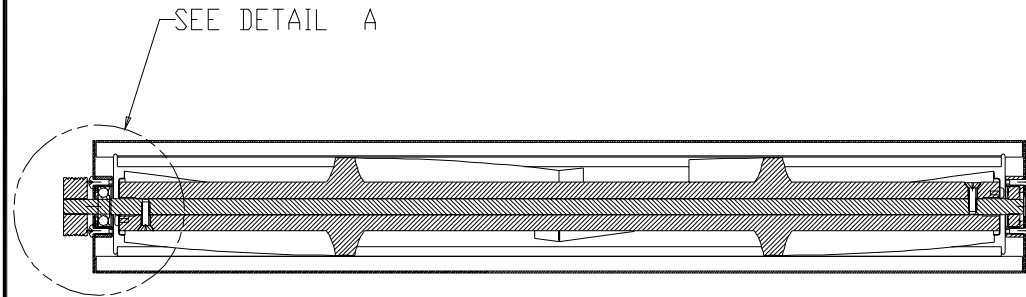

SECTION A-A

REV	DATE	ECN	DESCRIPTION	BY	MATERIAL	FINISH	TACOONY		3101 Wichita Court Fort Worth, TX 76140-1755	
E	06/07	10741	REMOVED 19988	TNC	DWN OM	DATE 05/98	SCALE NTS	SHEET 1 OF 1	COMMERCIAL FLOOR CARE	
D	02/00	10297	REMOVED 19937 & 19906 ADDED 07535 & 19948	XAZ	UNLESS OTHERWISE NOTED ALL TOLERANCES ARE ±0.02		TACOONY CORPORATION CLAIMS PROPRIETARY RIGHTS IN THE MATERIAL DISCLOSED HEREIN. THIS DRAWING IS ISSUED FOR ENGINEERING INFORMATION ONLY. IT MAY NOT BE REPRODUCED, NDR MAY THE INFORMATION HEREIN BE USED FOR MANUFACTURING PURPOSES WITHOUT WRITTEN PERMISSION FROM TACOONY CORP.		DESCRIPTION ASSY, BRUSH, WAV	
C	12/99	10104	REMOVED 19948	TH			A	PART NUMBER	19870	REV 0